

# Vehicle Brake & Clutch Bleeder Kit

## Features of the product:

- Quick, easy and effective bleeding of brakes and clutch using air from the spare wheel.
- Innovative design incorporates valve control of air pressure.
- Extra-long hose for use with larger vehicles and magnetic reservoir base to prevent accidental spillage.
- Suitable for use with ABS systems.
- Supplied with a range of common adaptors.



## Safety Instructions

- Keep this product in good working order and condition, take immediate action to repair or replace damaged parts.
- Use approved parts only. Unapproved parts may be dangerous and will void the warranty.
- Keep children and unauthorised persons away from the work area.
- Keep work area clean and tidy and free from unrelated materials.
- Ensure the work area has adequate lighting.
- Do not use the kit to perform a task which it is not designed for.
- Do not allow untrained individuals to use the kit.
- Do not use the tool when you are tired or under the influence of drugs, alcohol or intoxicating medication.
- Dispose of waste liquids in accordance with local authority regulations.
- Always read and comply with the warnings on the brake fluid container.
- Wear eye protection and avoid contact with the fluid. If brake fluid gets into your eyes, rinse with plenty of water and seek medical advice. If swallowed, seek medical advice immediately.
- **Warning! Only use new brake fluid. Used brake fluid or other fluids will contaminate the system and possible brake system failure may occur.**
- **Warning! Do not discharge fluids in an uncontrolled way, by which the environment will be polluted.**
- **Warning! Brake fluid is flammable - keep it away from sources of ignition, including hot surfaces e.g. exhaust manifold.**
- **Warning! Brake fluid will damage the paintwork. Any spillage should be flushed with water immediately.**

## Parts List

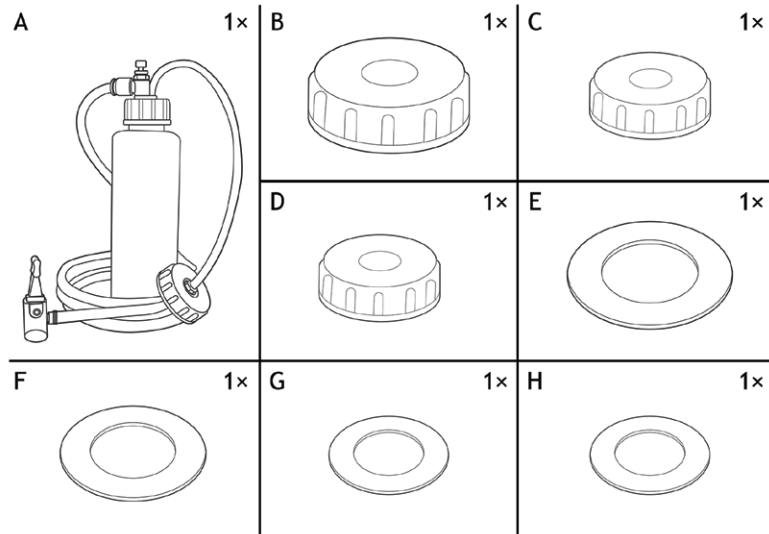

## Brake Bleeding Procedure

Refer to the vehicle manufacturer's instructions for brake bleeding and wheel arrangement before proceeding. If no specific instructions from the vehicle manufacturer exist, follow the instructions detailed below.

**Warning! Familiarise yourself with the hazards of brake fluid - read the manufacturer's instructions on the container.**

*Note: Ensure that the brakes are adjusted before proceeding with bleeding the brakes.*

1. For vehicles fitted with servo assisted brakes, pump the brake pedal two or three times with the engine switched off, to evacuate the air from the servo.

2. Remove the reservoir cap from the vehicles brake master cylinder, select and fit the appropriate adaptor cap to the automatic brake bleeder and connect the adaptor to the master cylinder.

3. Adjust the tyre pressure of the spare wheel or one of the vehicles tyres to a maximum of 20 psi and connect it to the automatic brake bleeder. (The use of the spare wheel is recommended.)

4. Carry out a pressure test on the bottle with no brake fluid to ensure the bottle has no leaks and then release the pressure, disconnect it from the tyre and fill the pressure bottle with new clean brake fluid.

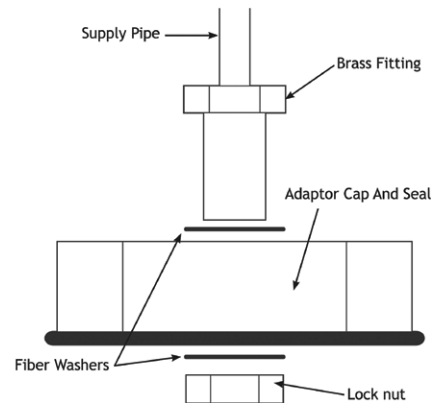

Fig. 1

**Warning! Do not over-tighten the pressure bottle cap. Check that the seal is correctly seated in the cap before use and screw it onto the pressure bottle until it contacts the seal. Do not tighten it more than 1/8th of a turn after this contact point.**

5. Ensure the regulator on the top of the bottle is on the closed position before you connect the air line to the tyre (see fig. 2). Ensure that the pressure bottle is in a safe upright position.

6. Slowly open the regulator anti-clockwise to pressure the brake system, checking to ensure there are no leaks.

*NOTE: The 20 psi quoted are for guidance only. A pressure as low as 10 psi can successfully bleed the brakes. Adjust the regulator valve according to the vehicle being worked on.*

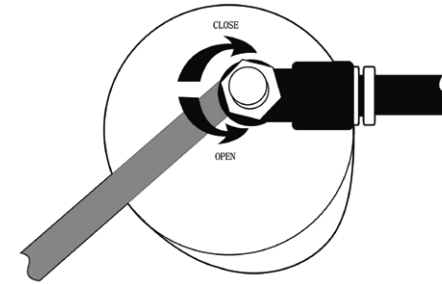

Fig. 2

7. Starting from the bleed nipple that is furthest away from the master cylinder, attach a bleed tube and place the other end into a suitable container. Loosen the bleed nipple (see fig.3) to allow the old brake fluid to flow into the container. When the fluid is clean and free from air, re-tighten the nipple.

*NOTE: When the brake bleeding and/or fluid changing is complete, test the action of the brake pedal to ensure that the brakes are working correctly and the pedal does not feel spongy before using the vehicle on the road.*

8. Repeat the operation for the remaining bleed nipples in the order recommended by the manufacturer.

9. When the bleeding operation is complete, disconnect from the tyre BEFORE removing from the brake master cylinder.

10. If required, top up the brake fluid in the reservoir to the maximum level and replace the original reservoir cap.

11. After use, re-pressure the tyre to its normal operating pressure for future use.

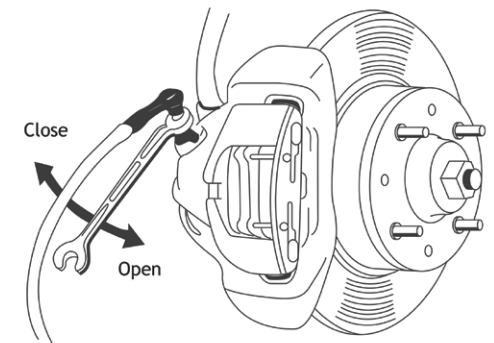

Fig. 3



## Tandem Master Cylinder Systems

Some vehicles require two lines to be bled simultaneously (normally one front and one rear), in this situation open both bleed nipples and control the flow using the regulator on the top of the pressure bottle.

## Uncommon Brake Systems

In some cases, the master cylinder outlet is below the inlet, this may require pumping the pedal once or twice in conjunction with the pressure bleed to remove any trapped air bubbles. Alternatively the vehicle can be jacked up to raise the outlet.

## Clutch Bleeding Procedure

Refer to the relevant vehicle manufacturer's instructions for the clutch bleeding procedure. If no specific instructions from the vehicle manufacturer exist, the same procedures as for brake bleeding applies.

## Cleaning & Maintenance

- Before carrying out any maintenance, ensure that the unit is de-pressurised and all fluids are drained from the pressure bottle and tubes.
- Clean up any spilled brake fluid and wipe down with a clean cloth.
- Store in a clean, dry and childproof location.

### **Streetwize Accessories:**

Unit 1, Royce Trading Estate, Ashburton Road West,  
Trafford Park, M17 1RY.

---

**Sales enquiries:** [sales@streetwizeaccessories.com](mailto:sales@streetwizeaccessories.com)

**Technical enquiries:** [support@streetwizeaccessories.com](mailto:support@streetwizeaccessories.com)

[www.streetwizeaccessories.com](http://www.streetwizeaccessories.com)