



# Solar Cascading Slate Water Feature

With Back-Up On-Demand Lithium Battery

GW280

## Information For Use



*To get the best use of this water feature, we highly advise that you read all the information and safety guidelines in this document.*

# Contents

1. Gardenwize Cascading Slate Solar Water Feature
2. LED Light
3. Solar panel with On Demand Lithium Battery
4. Water pump
5. Stake for solar panel

---

## Positioning This Solar-Powered Water Feature

When placing this water feature, ensure the solar panel is placed where it can get the most direct sunlight.

Avoid positioning the solar panel in an area where there is a lot of shade as this will affect the performance.

---

## Assembly Instructions

Please follow the instructions below:

1. Remove the product from its packaging.
2. Place the water feature in a location where the solar panel can receive plenty of direct sunlight.
3. Connect the pump to the integrated tube. Then, thread both wiring of the LED and water pump through the opening behind the unit (see figure 1).

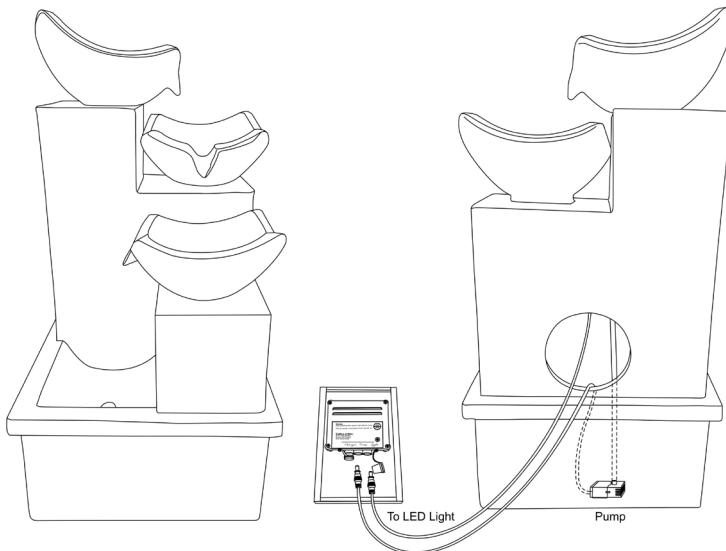
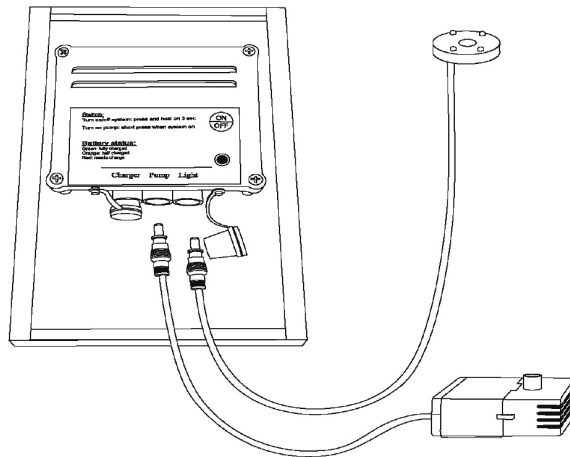

Figure 1

4. Connect the wiring for both LED light and water pump to the solar panel (see figure 2). Please note, the charge port for this product is not used. And this water feature is not supplied with a charger cable and it is also not available to purchase. Please ensure this charge socket is well covered to prevent rain/moisture entering.



*Figure 2*

5. Attach the stake to the back of the solar panel (see figure 3) and then secure it into soft ground. Ensure the panel is well-positioned where it can get direct sunlight during the day.

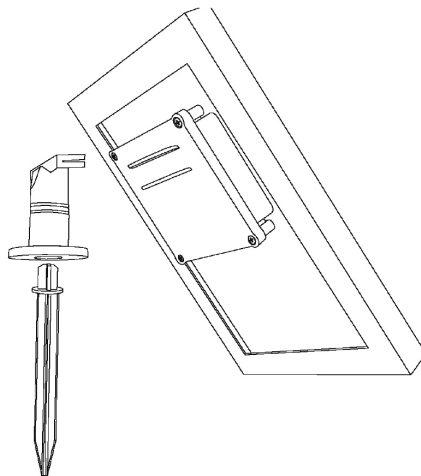

*Figure 3*

6. Fill the basin with water. The water level should be below the opening at the back of the unit. Ensure both the water pump and LED light are immersed in the water.

## On First Use

The built-in back-up lithium battery in this product will have been 70% to 80% charged upon manufacture. However, on the date of purchase, the battery will lose its charge during shipping and storage. For best results, allow the solar panel to charge the battery for a full day in direct sunlight before using the pump.

---

## Direction for Use

This water feature is designed to run during the day in direct sunlight. Any excess power produced via the solar panel will be used to charge the back-up battery. This will allow for running of the pump and LED light in the evening. Please note, the evening runtime will vary depending on charge level of battery and weather conditions.

The LED light automatically illuminates in the evening, if there is sufficient charge in the battery.

### How to Turn On The Unit

---

To turn on the unit to start running the pump and the LED light, place your finger on the 'on/off' button on the rear of the solar panel for 1 second.

### How to Charge The Lithium Battery

---

To switch off the pump, place your finger on the 'on/off' button on the rear of the panel for 3 seconds to turn off the pump. When the pump/LED light is switched off, all of the charge generated by the solar panel will be stored in the back-up battery.

Please note, this may have to be done periodically during inclement weather.

### Battery status

---

On the reverse side of the solar panel, there is LED indicator light that will show you the battery charge status.

<b>LED Colour</b>	<b>Status</b>	<b>Pump Run Time</b>
Green	Battery is fully charged	4 to 6 hours
Orange	Battery is at 50% charged	2 to 4 hours
Red	Battery is less than 20% charged	Up to 1 hour

# Cleaning and Maintenance

## Pump

---

If the pump stops working or is running slow, you will need to disassemble and clean the pump to remove any debris/limescale from the filter and motor chamber, as shown below:

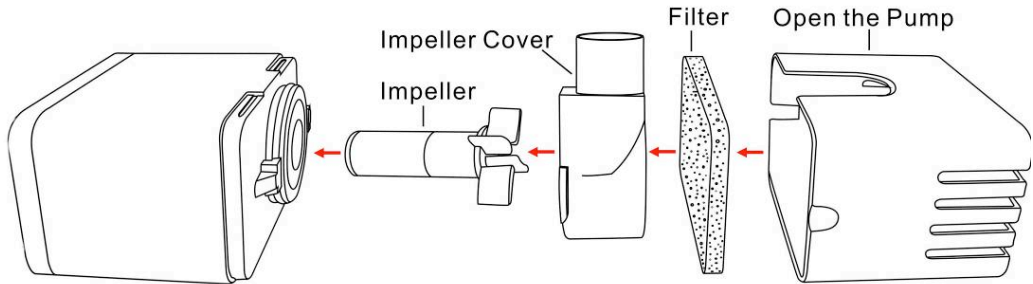

Figure 4

To disassemble the pump, ensure the unit is switched off. Remove the pump from the water tube and take the pump out of the water. Then, remove the pump cover, filter and impeller cover (figure 4). Clean them with fresh water and place them back inside the pump.

## Solar Panel

---

The solar panel should be cleaned with a soft cloth on a regular basis to maintain an optimum efficiency.

## Safety Warnings

---

- Do not strike the solar panel.
- Do not let the pump run dry for long time.
- Do not lift the pump by the power cord.
- Only use freshwater when using this water feature.

## Storage

---

Ensure the battery is fully charged before storing and disconnecting all cables. We recommend the use of a cover to protect the water feature from dust/damage.

# Troubleshooting

<b>Troubleshoot</b>	<b>Potential Cause</b>	<b>Pump Run Time</b>
Pump not operating under full sunlight.	Pump is not connected to the solar panel. Impeller is blocked - to clean the pump, remove the front plate and the impeller. Use a small brush or fresh water to remove any debris.	Check connection to the solar panel. Remove blockage (see cleaning and maintenance).
Pump is operating but water is not running through the	Build-up of sediment or limescale inside the pump.	Clean tubes and filter (see Cleaning and Maintenance)

# Pump Performance In Different Weather Conditions

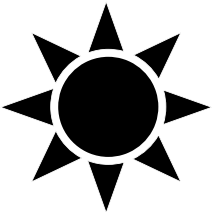
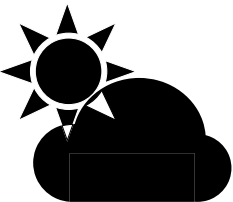
<b>Weather</b>	<b>Pump On</b>	<b>Pump Off</b>
	Solar energy runs the pump and charges the battery. Pump performance is maintained when brief cloudy conditions occur. Pump runs up to 5 hours in the evening.	Battery should be fully charged in 1 day.
	Solar energy runs the pump and supplies some energy to the battery. Performance is maintained when the clouds pass. Pump will only run a shorter period of time in	Battery will take 2 to 3 days to fully charge.

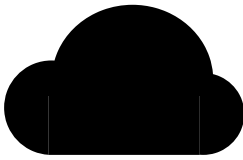

Pump will only run when there is sufficient power from the battery. Little or no battery charging occurs so pump performance is not maintained.

Battery will take several days to fully charge.

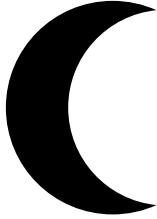

No solar power is available, the pump will not run and battery will not charge.

Battery will not charge.

---

## Technical Specification

Product	Gardenwize Cascading Slate Solar Water Feature
Supplier Code	GW280
Solar Panel	3W
Operation Voltage	9V
Water Flow Max	250LPH
Water Lift Max	1.0M
LED Light	3pcs LED Light
Cable Length	5M
Lithium Battery	7.4V-2000 mAh



**Streetwize:** Ashburton Road West, Trafford Park, Manchester, M17 1RY  
[www.streetwizeaccessories.com](http://www.streetwizeaccessories.com)

---

**For Product Support:**

**E:** [support@streetwizeaccessories.com](mailto:support@streetwizeaccessories.com)

**T:** +44 (0)161 447 8597

**For Trade Enquiries:**

**E:** [sales@streetwizeaccessories.com](mailto:sales@streetwizeaccessories.com)

**T:** +44 (0)161 447 8580

---

**EU Registered Address:** Ace Supply Co (Europe) Ltd, 25 Herbert Place, Dublin 2, D02 A098 Republic of Ireland.