

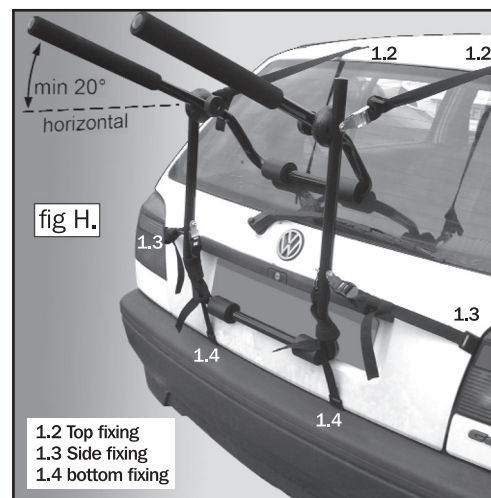

### Hatchbacks & Estate Cars

When securing the carrier to the vehicle ensure that the straps are not twisted. Straps must be progressively tightened alternately and equally ensuring the carrier is centrally positioned. Attach straps in following order top, bottom and then sides.

- 3.1 To fix upper straps to vehicle, we recommend that you hook the straps onto the top edge of the tailgate, see fig H (1.2) and adjust the length of the the straps to allow the carrier to hang in place at the required height.
- 3.2 Attach the bottom straps to the lower edge of the tailgate. Equally tighten the straps, see fig H (1.4)
- 3.3 Attach the side straps to a suitable position on either side of the rear hatch or door and equally tighten the straps. See fig H (1.3).
- 3.4 Adjust all straps to finally position carrier ensuring that the protection pads (RED) on the cycle carrier from are firmly in contact with the vehicle bodywork.
- 3.5 Re-check all straps and fully tighten.



**For additional security 4 x Cycle Fixing Straps are supplied to secure the cycles to the cycle carrier frame. Please ensure these are knotted tightly to avoid damage to vehicle or cycles.**

### Placing Cycles on Carrier:

- 4.1 A maximum of two bicycles can be placed onto the carrier support arms. Place them in opposite directions. To avoid damage do not position them directly next to the vehicle's exhaust, especially the bicycle tyres. Secure bicycles to the carrier with the thin straps provided. **DO NOT** use string or elasticated straps. Ensure that the bicycles, especially the pedals, do not come into contact with the vehicle's bodywork.
- 4.2 Place the cycles on the carrier arms as indicated on fig I. depending on male or female type frame.
- 4.3 If only one cycle is being used on the carrier, please tie the front wheel securley to the cycle frame using one of the straps provided, to ensure there is no movement of the front wheel of the cycle when the vehicle is moving.
- 4.4 When you have secured the bicycles on the carrier, check and re-tighten all the straps and tie off the surplus lengths of strap for extra security and to prevent the loose ends flapping.

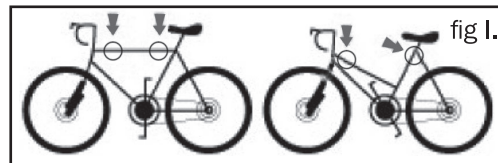

**WARNING!** Remember the driver of the vehicle is responsible for the security and safety of the load carrier. Check the tension of all straps and security of the bicycles frequently during your journey. If your lights or number plate are obscured, you must fit an auxiliary number plate and/or lighting system.

**No liability is accepted by the manufacturer or supplier for incorrect use of the product as described in these instructions.**

**Streetwize Accessories: Sales enquiries:** sales@streetwizeaccessories.com

**Technical enquiries:** support@streetwizeaccessories.com www.streetwizeaccessories.com

# Universal Adjustable Twin Cycle Carrier

SWCC2



### Safety Instructions.

Please therefore read all instructions and warnings carefully and retain instructions for future reference and ensure that other users are familiar with the content of this document. The supplier or manufacturer is not responsible for damage caused by incorrect fitting of the bike carrier. It is therefore essential that the carrier is fitted correctly to vehicle.

To ensure compliance with road traffic regulations, the use of a lighting board or additional number plate is required if you vehicles lights/ number plate are obscured by the carrier. This is particularly important for vehicles with high mounted rear lights.

Read the instructions before installing. Do not mount the cycle carrier if you're not sure you understand these instructions. Incorrect installation may result in damage to cycle, cycle carrier, or the vehicle. When the cycle carrier is attached to a vehicle, do not use if the wind speed exceeds 80km/hr.

**Never exceed the maximum 2 cycles (30kg) recommended load.**

**Unpack product and check contents against the contents list.**

**Should there be any damaged or missing parts contact your supplier immediately.**

- Do not use carrier if any parts are missing or damaged.
- Use the supplied cycle fixing straps for securing cycles to the carrier. Do not use string or elasticated straps.
- If you are going on a long journey, periodically stop and check that the fixings are tight. Always drive with extra care when a cycle carrier is attached and remember your vehicle is considerably longer when parking or reversing. It is recommended to remove the cycle carrier when not in use and if you are using a car wash.
- Improper adjustment or misuse of the cycle carrier can be dangerous and result in damage to the bicycles, the vehicle and other vehicles.
- Check that the wheels of your bicycle do not interfere with the exhaust pipe, the heat could damage your bicycle wheels.
- Do not use this product when it shows signs of wear. Straps and bolts can be replaced.
- Before commencing your journey check the cycle carrier is in the correct position and that all the restraining straps are secure as the weight of the cycles could loosen the straps after fitting.

#### Contents List

- 1 x Main Frame (part assembled)
- 6 x Fixing Straps
- 4 x Cycle fixing straps
- 2 x Fixing bolts with washers and nuts
- 4 x Black plastic buckles
- 4 x Metal clamps



- Ensure that bicycles do not come into contact with the vehicle bodywork and provide protection as required.
- For hatchbacks and estate vehicles ensure the foam protection pads make contact should the carrier's arms rest on the rear window.
- For hatchback vehicles with glass edges you must ensure the glass is protected by some form of rubber strip or pad.
- This carrier is designed to carry 2 cycles. Check the vehicle manufacturer's specification to ensure that you do not overload the rear hatch door.
- **WARNING!** Remove any loose objects from the cycles i.e pumps, bottles etc.
- **WARNING!** Avoid any protrusions beyond the side of the car as these may present a risk of injury to passers-by.
- **DO NOT** use the cycle carrier for any purpose other than for which it is designed.
- **DO NOT** strap any other items to the carrier, only bicycles.
- **WARNING!** Drive carefully - Be aware of cross winds, sudden braking or hard cornering, reduce speed accordingly when using carrier.
- **WARNING!** This carrier is designed for temporary use only, remove when not in use or before going through a car wash.
- **WARNING!** Remember the driver of the vehicle is responsible for the security and safety of the load carried.

### Carrier assembly instructions:

- 1 The cycle carrier's main frame comes part assembled and folded flat.
- 2 The side and bottom mounting anchors share the same fixing bolts and need to be assembled to the lower part of the frame as seen in fig A.
- 3 Hook a metal mounting anchor through each black plastic buckle as shown in fig B, and compress the open end of the anchor as much as possible by hand.
- 4 Push a fixing bolt through the two holes in one of the metal anchors and slide the bolt through one of the holes in the main frame from the outside. Ensure that the black buckle is curving away from the frame.
- 5 Slide another metal anchor/plastic buckle assembly over the bolt protruding from the frame ensuring again that the black buckle is curving away from the frame.
- 6 Place a washer over the end of the bolt and compress the assembly enough to be able to thread a nut onto the end of the bolt. Using two M10 spanners compress the assembly until the open ends of the fixing anchor are pressed together as shown in fig A. 1.1
- 7 Assemble the two remaining metal anchor/plastic buckle assemblies to the other side of the frame in a similar manner.
- 8 Unfold the main frame by loosening the two clamping knobs seen in fig A until the clamping cups spring apart. Unfold the frame to the approximate position shown in fig A. Re-tighten the clamping knobs so that the clamping cups are firmly together.

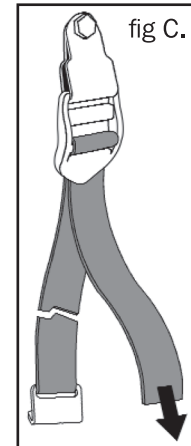
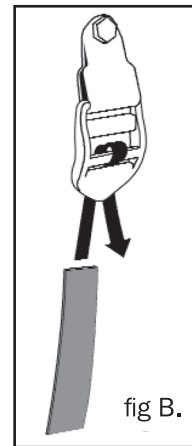
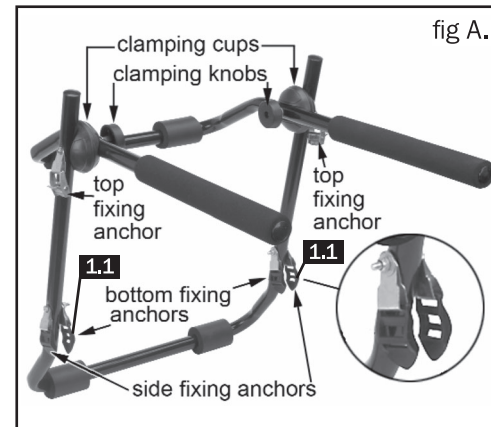

- 9 The padded support legs should be angled upwards by at least 20° from the horizontal when the frame is attached to the vehicle. The actual angle between the two parts of the frame will vary depending on whether the car is a hatchback, an estate or a saloon with a boot. See figs G & H.
- 10 It is important that the fixing straps are threaded the correct way through the black plastic buckles in order for them to remain tight. See fig B.
- 11 Thread a strap through each of the bottom and side buckles as shown in figs B & C. The fixing hooks on the end of the straps should be facing backwards as shown in fig. C.
- 12 Attach the remaining two straps to the top anchor fixings as shown in fig A. The metal clips are spring loaded shut as shown in fig D. Hold the clip open with your thumb as shown in fig E and thread the strap through from the back. Release the clip to grip the strap as shown in fig F. The fixing hook at the end of each strap can be orientated either way round.

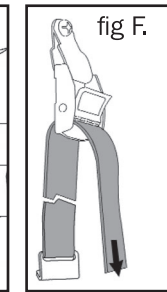
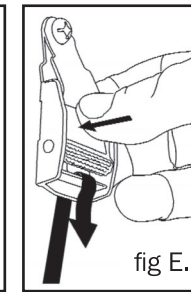
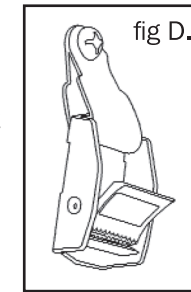

### Carrier fitting instructions:

This load carrier is universal for fitting to most vehicles. As with all universal products, there may be exceptions such as 4x4's with mounted spare wheels. If in doubt, do not use this item.

#### Preparing the Carrier

- 1 Position the carrier on the rear of your vehicle and adjust the carrier arms as shown in fig G & H (OVERLEAF).
- 1.1 The arms should be at a minimum angle of 20° above the horizontal. See section 9 (see carrier assembly instructions) regarding adjustment of the arms.

#### Saloon Cars

When securing the carrier to the vehicle ensure that straps are not twisted. Straps must be progressively tightened alternately and equally ensuring the carrier is centrally positioned. Attach straps in order, top, bottom, and then sides as follows:

- 2.1 To fix upper straps to vehicle, we recommend that you hook the straps onto the top edge of the boot lid, see fig G (1.2) and adjust the length of the straps to allow the carrier to hang in place at the required height.
- 2.2 Attach the bottom straps to the lower edge of the boot lid, or other adequate securing point on the vehicle bodywork. Equally tighten the straps, see fig G (1.4)
- 2.3 Attach the side straps to a suitable position on either side of the boot lid and equally tighten the straps. See fig G (1.3).
- 2.4 Adjust all straps to finally position carrier ensuring that the protection pads are firmly in contact with the vehicle bodywork.
- 2.5 Re-check all straps and fully tighten.

