



LW602

**CLEANING & MAINTENANCE:** After each use of the Yoga Grill we advise that you clean the product to ensure longevity of the product's life.

To clean after using the Yoga Grill, please allow it to fully cool down. Then lift the iron rack from the charcoal box and then carefully lift the charcoal box from the ignition plate (Note: When doing so, some of the charcoal's ash will spill over into the grill's main body). Dispose the charcoal ash in line with guidance from your local authority. Then finally remove the ignition plate from the yoga grill.

With a suitable brush, remove all the excess charcoal ash from the grill's main body.

Then wash the iron rack, charcoal box and ignition plate using warm water and washing up liquid. Do not use harsh chemical cleaners or abrasive cleaners. Dry using a soft clean cloth.

**Important: If you are not going to use the Yoga Grill for a prolonged period of time, we highly advise that you remove the batteries from the fan box to prevent any leakage from the battery.**

Once the grill and its components have been cleaned (and the components have been fully dried), place the grill and its component parts inside the storage bag supplied. Then store in a cool and dry place.

**HEALTH & SAFETY:**

This Yoga Grill is not a toy. Ensure children are fully supervised when you are using the product. Never touch the Yoga Grill when in use, as the surface, especially the iron rack, will become very hot. Risk of personal injury and burns.

When using the Yoga Grill, use suitable protective equipment when handling and cooking the food.

DO NOT use the yoga grill indoors.

DO NOT block the air vent in the main body of the grill.

Keep the product on a flat surface during BBQ.

**TECHNICAL SPECIFICATIONS:**

<b>Product Name</b>	Leisurewize Yoga BBQ Grill
<b>Supplier Code</b>	LW602
<b>Iron Rack Diameter</b>	310mm
<b>Dimension (approx)</b>	320mm x 230mm
<b>Battery Requirements</b>	4 x AA batteries
<b>Battery run time</b>	Up to 2 hours



**Streetwize:** Ashburton Road West, Trafford Park,  
Manchester M17 1RY

**For product support:** E: [support@streetwizeaccessories.com](mailto:support@streetwizeaccessories.com)  
T: +44 (0)161 447 8597

**For trade enquiries:** E: [sales@streetwizeaccessories.com](mailto:sales@streetwizeaccessories.com)  
T: +44 (0)161 447 8580

**For spare parts:** E: [spareparts@streetwizeaccessories.com](mailto:spareparts@streetwizeaccessories.com)

**or contact us on our online form:**  
[www.streetwizeaccessories.com](http://www.streetwizeaccessories.com)

We have over 1000 car & leisure products in our range. To find out more follow us on social media.

Search "Streetwize"



# Yoga Grill

COOKS FOR UP TO 6 PEOPLE



**PLEASE READ THESE INSTRUCTIONS BEFORE OPERATING THIS SMOKELESS, PORTABLE, CHARCOAL BBQ GRILL AND KEEP FOR FUTURE USE. THIS PRODUCT CAN ONLY BE USED OUTDOORS IN A WELL VENTILATED ENVIRONMENT. NEVER USE IT INDOORS AS BURNING CHARCOAL WILL CAUSE CARBON MONOXIDE POISONING.**



### INTENTION FOR USE

Thank you for purchasing this Yoga BBQ Grill from Leisurewize. This product is intended for BBQ grilling and can cook for up to 6 people. It is perfect for use during caravan breaks, camping holidays or even for al fresco dining.

This grill is battery-operated, making it a portable but effective BBQ grilling solution. It has an adjustable air fan that controls the heat coming from the charcoal. It also features a Type C USB port for connecting to a power supply when the battery is low.

This appliance should not be used indoors, it is only suitable for outdoor dining due to the smoke coming from the charcoal.

### PRODUCT SPECIFICATION

1. Iron Rack
2. Charcoal box
3. Ignition plate
4. Yoga grill's main body
5. Battery-powered fan box
6. Storage case



### POWERING THE YOGA GRILL

This Yoga Grill can be battery operated, or it can be operated via its Type-C USB charge port. The Yoga Grill takes 4 x AA batteries which go inside the fan box. The USB charge port is also located on the fan box, and can be used if the battery level is low or depleted.

Please note, when using a Type-C USB charge port, you need to use a Type-C USB charging cable (not included) and connect it to a USB charge socket (not included).

### HOW TO USE THE GRILL

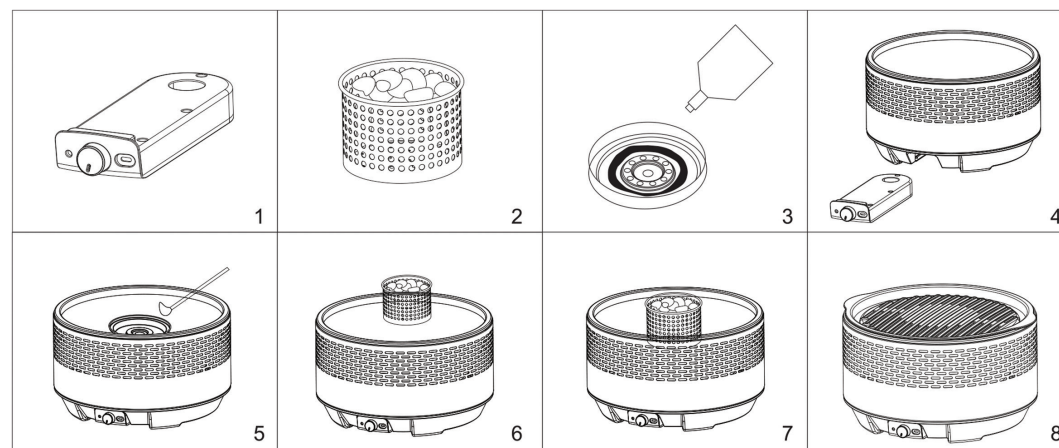

1. Remove the battery-operated fan box from the yoga grill, and insert 4 x AA batteries (not supplied).
2. Take the charcoal box, and fill it with charcoal. Please note: Do not overfill the charcoal box, fill to just below the opening.
3. Put fire gel (not supplied) onto the ignition plate. Then, place the ignition plate inside the yoga grill. NOTE: DO NOT use too much fire gel.
4. Place the fan box back into the yoga grill.
5. Ignite the fire gel using a suitable BBQ/Kitchen lighter.
6. Place the charcoal box over the ignition plate. Warning: Please take extra care when placing the charcoal box on top of the ignition plate. Please use heat proof equipment such as heat protective gloves.
7. Turn the temperature control dial on the fan box to its maximum level.
8. Place the iron grill rack on the top.

Once the charcoal has fully heated up, the Yoga Grill is ready for grilling your food.

When using the grill, adjust the heat via the temperature control dial found on the battery-powered fan box.