

6 in 1 Portable Power Station & Emergency Jumpstarter

Air Compressor, 1x Inverter Socket, LED Work Lights, 2x12V & 1xUSB Power Socket



The Emergency Jumpstart is suitable for Petrol vehicles up to 2500cc & Diesel vehicles up to 2000cc

**18Ah Battery
650 Amps (Peak)
350 Amps (Continuous)**

When unpacking, make sure that the product is intact and undamaged. If any parts are missing or broken, please contact the point of purchase as soon as possible. All images are for illustration purposes only actual product may differ slightly. PLEASE READ AND UNDERSTAND THESE INSTRUCTIONS BEFORE ANY USE IS ATTEMPTED AND RETAIN FOR FUTURE REFERENCE.

IMPORTANT WARNING: This product is only supplied with a minimal amount of charge at manufacture, therefore for this product to operate correctly it has to be fully charged for a period of 24 hours **IMMEDIATELY** after purchase, this is essential **BEFORE ANY USE!** & cannot be used **DURING** the charge period. Failure to adhere to these conditions may invalidate the products warranty. **ALSO:** Fully recharge periodically every (1-2 months) to help prolong the battery life (see page 7).





Table of Contents

SAFETY

Safety	2	Maintenance.....	12
Specifications	5	Parts List and Diagram.....	14
Setup.....	6	Warranty.....	16
Operation.....	10		



SETUP

WARNING SYMBOLS AND DEFINITIONS

	This is the safety alert symbol. It is used to alert you to potential personal injury hazards. Obey all safety messages that follow this symbol to avoid possible injury or death.
	Indicates a hazardous situation which, if not avoided, will result in death or serious injury.
	Indicates a hazardous situation which, if not avoided, could result in death or serious injury.
	Indicates a hazardous situation which, if not avoided, could result in minor or moderate injury.
	Addresses practices not related to personal injury.

OPERATION

V	Volts
~	Alternating Current
A	Amperes
CCA	Cold Cranking Amps
RC	Reserve Capacity
Ah	Ampere-hours

	WARNING marking concerning Risk of Eye Injury. Wear ANSI-approved splash-resistant safety goggles.
	Read the manual before set-up and/or use.
	WARNING marking concerning Risk of Fire. Follow connection procedure.

MAINTENANCE

General Safety Warnings

▲WARNING

Read all safety warnings and instructions.
Failure to follow the warnings and instructions may result in electric shock, fire and/or serious injury.
Save all warnings and instructions for future reference.

WARNING – RISK OF EXPLOSIVE GASES.

Working in vicinity of a lead-acid battery is dangerous. Batteries generate explosive gases during normal battery operation. For this reason, it is of utmost importance that you follow the instructions each time you use the Power Pack.

To reduce risk of battery explosion, follow these instructions and those published by battery manufacturer and manufacturer of any equipment you intend to use in vicinity of battery. Review cautionary marking on these products and on engine.

Work Area Safety

1. Keep work area clean and well lit. Cluttered or dark areas invite accidents.
2. Do not operate Power Pack in explosive atmospheres, such as in the presence of flammable liquids, gases or dust. The Power Pack can create sparks which may ignite the dust or fumes.
3. Keep children and bystanders away while operating the Power Pack. Distractions can cause you to lose control.
4. Store idle equipment. Always lock up tools and keep out of reach of children.

Electrical Safety

1. Do not drop a metal tool onto battery. It might spark or short-circuit battery or other electrical part that may cause explosion.
2. Do not operate if Power Pack has received a sharp blow, been dropped, or otherwise damaged in any way; take it to a qualified technician.
3. Do not leave Power Pack unattended while switched on. It could result in fire and property damage.
4. Do not expose to rain or wet conditions. Water entering the Power Pack will increase the risk of electric shock.
5. Do not use an extension cord with this item.
6. Use of an attachment not recommended or sold by the manufacturer may result in a risk of fire, electric shock, or injury to persons.
7. To reduce risk of damage to electric plug and cord, pull by plug rather than cord when disconnecting the Adapter.
8. Do not operate with damaged cord or plug. Replace the cord or plug immediately.

Personal Safety

SAFETY

-  Wear ANSI-approved splash-resistant safety goggles and heavy-duty rubber work gloves whenever connecting, disconnecting, or working near battery. Battery acid can cause permanent blindness. Avoid touching eyes while working near battery.
- Do not use Power Pack while you are tired or under the influence of drugs, alcohol or medication. A moment of inattention while operating Power Pack may result in serious personal injury.
- NEVER smoke or allow a spark or flame in vicinity of battery or engine.
- If battery acid contacts skin or clothing, wash immediately with soap and water. If acid enters eye, immediately flood eye with running cold water for at least 10 minutes and get medical attention immediately.
- Remove personal metal items such as rings, bracelets, necklaces, and watches when working with a lead-acid battery. A lead-acid battery can produce a short-circuit current high enough to weld a ring or the like to metal, causing a severe burn.
- People with pacemakers should consult their physician(s) before use. Electromagnetic fields in close proximity to heart pacemaker could cause pacemaker interference or pacemaker failure.

Service

Have your Power Pack serviced by a qualified repair person using only identical replacement parts. This will ensure that the safety of the Power Pack is maintained.

SETUP

Power Pack Safety Warnings

OPERATION

- Lead-acid batteries generate hydrogen gas when charging. Hydrogen gas is explosive. Only use the Jump-Start system in a well-ventilated area.
- Never exceed the maximum charging time of the Power Pack.
- Jump Starting A Vehicle
 - Use the Power Pack for jump starting a LEAD-ACID battery only.
 - For emergency use only. Do not use the Power Pack as a replacement for a vehicle battery.
 - Be sure area around battery is well ventilated while battery is being jump started.
 - NEVER jump start a frozen battery.
 - Do not attempt to jump start a vehicle with a non-rechargeable or defective battery.
 - Study all battery manufacturer's specific precautions for jump starting.
 - DO NOT TOUCH POSITIVE AND NEGATIVE BATTERY CLAMPS TOGETHER.**
 - Unplug the Power Pack from its Adapter before connecting its cables to a battery.
 - Connect and disconnect battery cable clamps only after setting any Jump Starter switches to OFF position.
 - Connect cables to proper polarities. Connect black cable to negative body ground and red cable to positive battery terminal.
 - Locate Power Pack as far away from battery as battery cables permit.
- Inverter
 - DO NOT OPEN HOUSING.** Contains no user-serviceable parts. Internal parts may be electrified, even with unit off.
 - Do not use the Inverter to power sensitive devices such as medical devices. Do not use in ignition protected areas.
 - Some rechargeable tools and appliances can damage the Inverter. Check the temperature of the device several times when it is charging. If the device becomes extremely hot; turn the power off, remove the device, and do not use with the Inverter again.
 - Do not attempt to power a device, or combination of devices, that will require more than the rated output of this Inverter. This may damage the Inverter or the attached devices..
 - Some fluorescent lamps may not operate properly with this type of Inverter. If the bulb appears to be too bright, or fails to light, do not use the lamp with this Inverter.
 - Some fans with synchronous motors may slightly increase in speed when powered by the Inverter. This is not harmful to the fan or to the Inverter.
 - Inverter will consume some power while on, even without loads attached. Turn Inverter off after use.
- Replace fuse with same type and rating only.
- Maintain labels and nameplates on the Power Pack. These carry important safety information.

MAINTENANCE

7. The warnings, precautions, and instructions discussed in this instruction manual cannot cover all possible conditions and situations that may occur. It must be understood by the operator that common sense and caution are factors which cannot be built into this product, but must be supplied by the operator.



SAVE THESE INSTRUCTIONS.

Specifications

AC Output Power	Continuous	350W
	Peak	650W
	Voltage	240V
	Frequency	60Hz
	Wave Form	Modified Sine Wave (non-sinusoidal)
Inverter No Load Current	<0.5A (battery drain with no load on Inverter)	
Battery	12V, 18Ah, Sealed Lead-Acid	

Booster Cables	26" L With Copper-Plated Clamps
Fuse	12V 40A
Low Voltage Warning	<10.8V - 11.3V
Low Voltage Shutdown	8.9V - 9.4V
Functions: 12 Volt Jump-Starter, 300 PSI Air Compressor, 200W Power Inverter, Power Supply, and Work Lights	



Read the **ENTIRE IMPORTANT SAFETY INSTRUCTIONS** section at the beginning of this manual including all text under subheadings therein before setup or use of this product.

Note: For additional information regarding the parts listed in the following pages, refer to Parts List and Diagram on page 14.

Functions

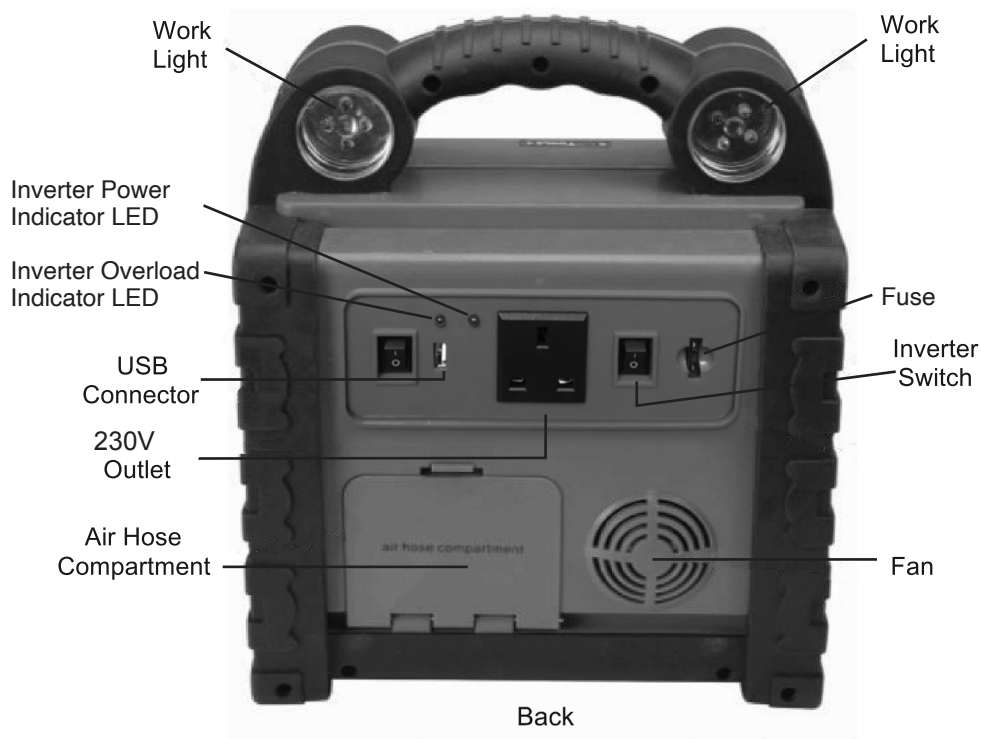
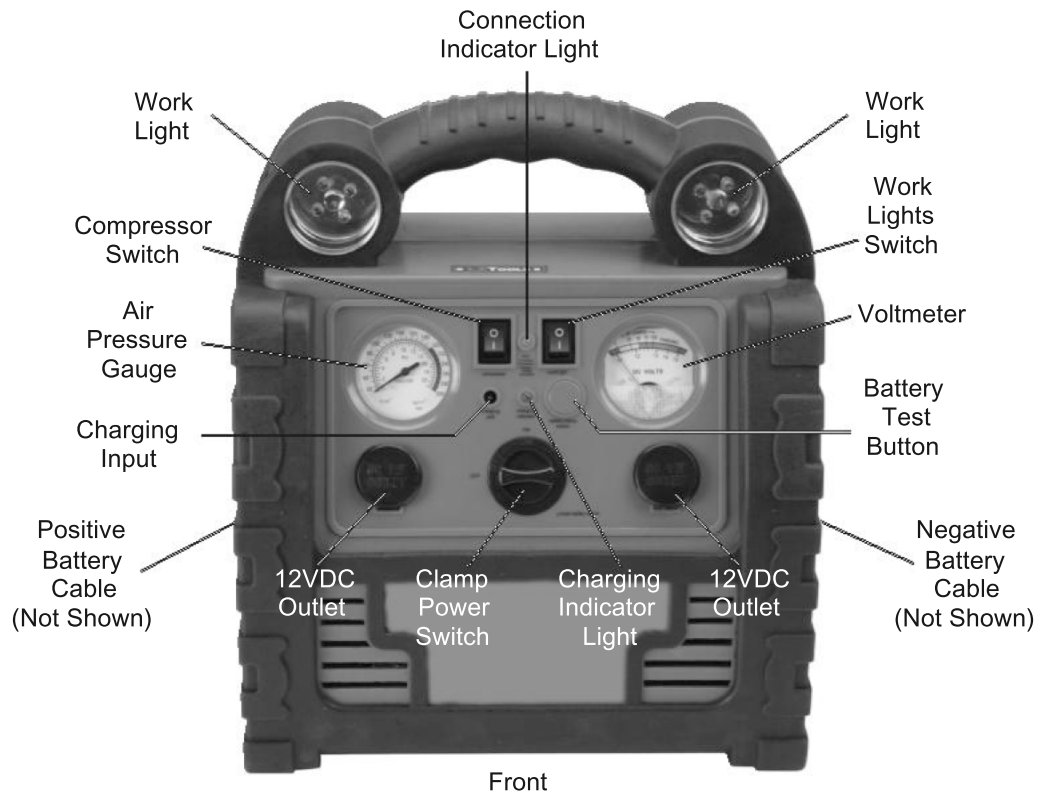

Figure A

Charging the Power Pack

WARNING! Always charge on a non-flammable surface.

1. Press and hold the Battery Test Button on the front of the unit to check the battery power level.
 - a. 13-15 volts is ready for use.
 - b. 12 volts needs to be charged.
 - c. Less than 12 volts should be charged immediately.
2. Turn the Clamp Power Switch on front of unit to the OFF position.
3. Plug the 230VAC Adapter into a 3-prong outlet. (See Figure B.)



Figure B

4. Plug the Adapter cord into the Charging Input on the front of the unit.

5. Allow the time needed to charge, periodically checking the Voltmeter.

Note: Before initial use, completely charge the Power Pack as indicated for Initial Charge. (See Figure C.)

AC Charge Time
Initial Charge: 24 hours
Recharge: when the gauge shows 40% or 12Volts 12 hours

Figure C

NOTE: FAILURE TO RECHARGE POWER PACK WILL VOID WARRANTY.

6. When the Power Pack is fully charged, unplug the Adapter from the outlet and the Power Pack.
7. Recharge for length of time as indicated for Recharge: (See Figure C.)
 - a. When voltage drops to 40% or 12Volts
 - b. After each Jump-Start.
 - c. 1-2 months (particularly in cold weather).
8. The Charging Indicator light will illuminate when the unit is charging. The Charging Indicator light will turn off when the charging is complete. The Voltmeter must be checked periodically when charging and the Power Pack must be unplugged when the unit is fully charged.

DO NOT EXCEED MAXIMUM CHARGING TIME.

AC Appliance Compatibility

SAFETY

The Power Pack has one Outlet for AC appliances. The total load from the outlet must not exceed the AC Outlet power listed in the Specifications Chart.

Some appliances may have a high initial surge which may make them incompatible with this unit. Calculate the total wattage needed to start up the appliances, and the total wattage needed to run the appliances before operation.

AC Output Power	Continuous	350W
	Peak	650W
	Voltage	240V
	Frequency	60Hz
	Wave Form	Modified Sine Wave (non-sinusoidal)

Figure D

To calculate the size of the load you plan to use with the Power Pack, use the following formula:

$$\text{Amps} \times \text{Volts} = \text{Watts}$$

For example, if you have an appliance whose running amps total 0.75 amps, you will need 180 watts of power ($0.75 \text{ amps} \times 240\text{V} = 180 \text{ Watts}$) to run the items continuously. This figure is within the capacity of the unit per "Continuous". (See Figure D.)

However, if the peak power for the items is 2 amps ($2 \text{ amps} \times 120\text{V} = 480 \text{ Watts}$), then the appliances are not suited to this unit. They will draw too much power for the unit to start the items per "Peak". (See Figure D.)

Always calculate the power needed to start up the appliances and to run them before attempting to use the Power Pack for AC appliances.

SETUP

OPERATION

MAINTENANCE

The following chart shows the estimated power to run some common appliances.

Note: Use this chart as a guideline only.

The actual power usage may vary based on the model or brand of the appliance. Check the actual wattage of your appliances and calculate the amount of power needed to start and run them. (See Figure E.)

Typical AC Appliances & Run Times		
Appliance (120VAC)	Estimated Power (Watts)	Estimated Lifetime (Hours)
• Fluorescent Lantern	15	7 hr.
• Electric Bug Killer	40	2 hr. 30 min.
• DVD player	60	1 hr. 45 min.
• Laptop • Radio	75	1 hr. 25 min.
• Electric Blanket	100	1 hr.

Figure E

The wattage rating of AC appliances is the average amount of power used by the unit. Items such as computer monitors, televisions and appliances with motors draw more power when they are first turned on than the amount of power that they use continuously.

The Power Pack supports a startup surge of up to 600 W, but some appliances exceed this level and will trigger the Inverter's power overload shut off feature, and cannot be used with this Inverter.

Modified Sine Wave

The Inverter can only power AC appliances which are compatible with a Modified Sine Wave (non-sinusoidal).

Note: Only multimeters identified as “TRUE RMS” will read Modified Sine Wave voltage accurately.

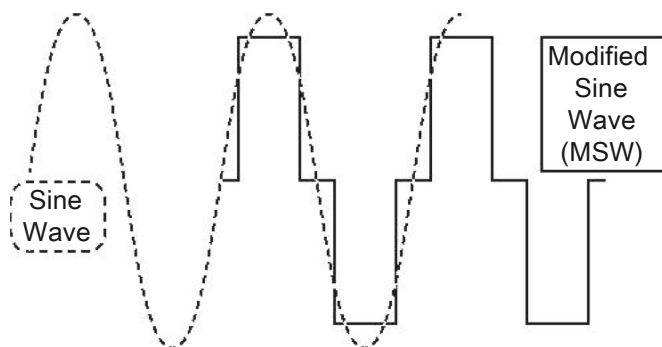

Modified Sine Wave power is suitable for most AC devices and power supplies used in electronic equipment, transformers, and motors.

DC Appliance Compatibility

The Power Pack can power a 12VDC auto, RV, marine, or other portable item that draws 12 amps or less. The lower the amount of watts the appliance uses, the longer the Power Pack can power it before needing to be recharged.

The Power Pack has two 12VDC Outlets. The total load from both outlets must not exceed 12 amps or 144 watts. Calculate the total wattage needed to run the appliances before operation. You do not need to calculate startup or surge wattages.

Inverter Overload Indicator

The Power Pack is equipped with an Inverter Overload Indicator Light which will illuminate when the battery reaches 11.3V, signalling that the battery is low and the unit will soon shut down to prevent damage to the battery.

Note: Do not use to power sensitive devices such as medical equipment.

Some audio equipment may perform poorly if run on Modified Sine Wave power. Some appliances can be damaged if used with this Inverter if they are not compatible with a Modified Sine Wave unit. Do not use with the following appliances:

- Electronic appliances which modulate RF (radio frequency).
- Chargers for batteries.
- Metal Halide arc lamps.
- Incompatible speed controllers in fans, power tools and kitchen appliances.

Note: if you are not sure if your appliance is compatible with this Modified Sine Wave Power Pack, check with the appliance manufacturer.

To calculate the size of the load you plan to use with the Power Pack, use the following formula:

$$\text{Amps} \times \text{Volts} = \text{Watts}$$

For example, if you have two appliances whose running amps total 7 amps, you will need 84 watts of power (7 amps x 12V = 84 Watts) to run the items. This figure is within the capacity of the unit.

If this happens, disconnect any loads in use and recharge the Power Pack.

Note: When the battery reaches 9.4V, power to the Outlets is automatically shut down.

Using the Work Lights

1. To turn the Work Lights on, push the Work Lights Switch to the "I" (ON) position.
2. To turn the Work Lights off, push the Work Lights Switch to the "O" (OFF) position.

Jump Starting a Vehicle

Note: Read the vehicle owner's manual pertaining to jump starting prior to using the Power Pack.

1. Press the Battery Test Button to verify that the Power Pack is fully charged. Recharge as needed, following the instructions in the Setup section under "Charging the Power Pack" on page 7.
2. Turn off the vehicle ignition switch and all accessories (lights, radio, climate control, etc.).

3. Turn all switches on the Power Pack to their OFF positions.

WARNING! DO NOT TOUCH POSITIVE AND NEGATIVE BATTERY CLAMPS TOGETHER.

3. Connect the red Positive Battery Cable to vehicle's positive battery terminal. Connect the black Negative Battery Cable to a non-moving metal part of the vehicle.

WARNING! DO NOT CONNECT TO THE NEGATIVE TERMINAL OF THE BATTERY.

4. The Connection Indicator Light will illuminate green if a correct connection has been made. If the Connection Indicator Light illuminates red, review and change the connections.
5. When the correct connection has been made, turn the Clamp Power Switch to the ON position.
6. WAIT FIVE MINUTES, then start the vehicle. If the vehicle does not start, wait an additional 3 minutes before trying again.

WARNING! THE VEHICLE WILL NOT START IF YOU DO NOT WAIT AT LEAST 5 MINUTES.

7. After the vehicle is started, turn the Clamp Power Switch to the OFF position. Remove the black Negative Battery Cable first, and then the red Positive Battery Cable.

Using the Air Compressor

1. Press the Battery Test Button to verify that the Power Pack is fully charged. Recharge as needed, following the instructions in the Setup section under "Charging the Power Pack" on page 7.
2. Open the Air Hose Compartment on the back of the unit and pull out the air hose.
3. Check the proper inflation level for the object that is being inflated.

Tire Inflation

1. Position the Tire Valve Adaptor over the valve stem and screw on to valve ensuring a good connection.
2. Push the Compressor Switch to the "I" (ON) position.

Note: Monitor the Air Pressure Gauge on the front of the unit to avoid over inflation.

3. When the proper inflation level has been reached, push the compressor switch to the (OFF) position.
4. Unscrew the Tire Valve Adaptor and remove the hose.

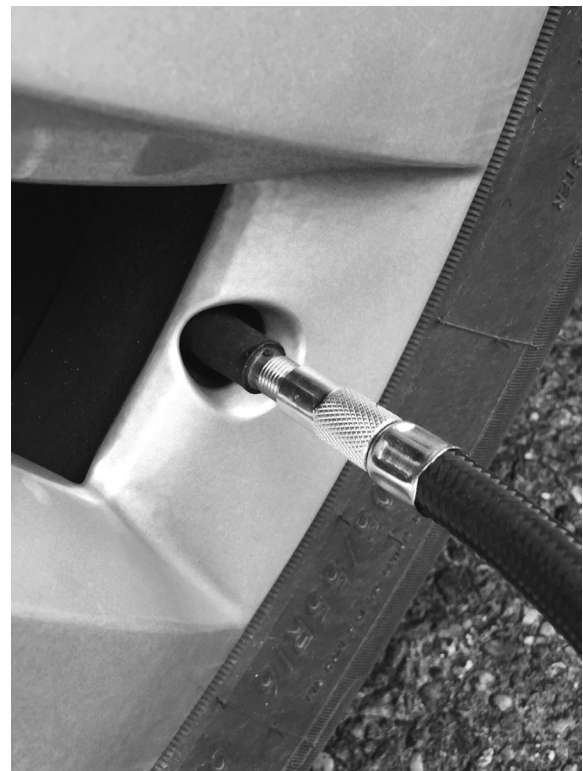

Using Hose Adapters

1. Three adapters are included with the Power Pack that can be attached to the Tire Inflator. (See Figure G.)



Figure G

2. Attach the proper adapter to the Tire Inflator for the object to be inflated.
3. Insert the adapter into the object's receptacle and screw on to tire valve.
4. Push the Compressor Switch to the "I" (ON) position.

Note: Monitor the Air Pressure Gauge on the front of the unit to avoid over-inflation.

5. When the proper inflation level has been reached, push the Compressor Switch to the "O" (OFF) position.
6. Unscrew the tire adaptor and remove the hose.

WARNING! Do not overinflate any object.

Powering AC Appliances

1. Press the Battery Test Button to verify that the Power Pack is fully charged. Recharge as needed, following the instructions in the Setup section under "Charging the Power Pack" on page 7.
2. Check to make sure the appliance or appliances are compatible with the Power Pack Inverter and the total wattage is within the range of the Power Pack. See Setup section under "AC Appliance Compatibility" on page 8.
3. Before connecting appliances, make sure the Inverter Switch is in the "O" (OFF) position.
4. Make sure that the appliance is off.
5. Plug the appliance into the 230V AC Outlet.
6. Push the Inverter Switch to the "I" (ON) position. If the Inverter is working correctly, the Inverter Power Indicator Light will illuminate.
7. Turn on the appliance, if the Inverter Power Indicator Light remains on, the system is functioning normally.
8. When finished using appliance, push the Inverter Switch to the "O" (OFF) position and unplug the appliance.

Powering DC Appliances

1. Press the Battery Test Button to verify that the Power Pack is fully charged. Recharge as needed, following the instructions in the Setup section under "Charging the Power Pack" on page 7.
2. Make sure the total wattage of the appliance or appliances is within the range of the Power Pack. See Setup section under "DC Appliance Compatibility" on page 9.
3. Before connecting appliances, make sure the Inverter Switch is in the "O" (OFF) position. Make sure that the appliance is off.
4. Plug the appliance into one of the 12VDC Outlets.
5. Push the Inverter Switch to the "I" (ON) position. If the Inverter is working correctly, the Inverter Power Indicator Light will illuminate.
6. Turn on the appliance, if the Inverter Power Indicator Light remains on, the system is functioning normally.
7. When finished using appliance, push the Inverter Switch to the "O" (OFF) position and unplug the appliance.

Charging USB Devices

1. Press the Battery Test Button to verify that the Power Pack is fully charged. Recharge as needed, following the instructions in the Setup section under "Charging the Power Pack" on page 7.
2. Before connecting the device, make sure the Inverter Switch is in the "O" (OFF) position.
3. Plug the device into the USB Connector.
4. Push the Inverter Switch to the "I" (ON) position. If the Inverter is working correctly, the Inverter Power Indicator Light will illuminate.
5. When the device is finished charging, push the Inverter Switch to the "O" (OFF) position and remove the device.



Procedures not specifically explained in this manual must be performed only by a qualified technician.

WARNING

TO PREVENT SERIOUS INJURY: Unplug the Power Pack, turn the Power Switch off and allow Power Pack to cool completely before performing any inspection, maintenance, or cleaning procedures.

1. BEFORE EACH USE, inspect the general condition of the Power Pack. Check for:
 - loose hardware,
 - cracked or broken parts,
 - damaged electrical wiring or cable insulation, and
 - any other condition that may affect its safe operation.
2. Keep unit clean and clamps free of dirt, debris, or grease.
3. For longer working life, protect Power Pack from sunlight and moisture.
4. Replace fuse with same type and rating only.
5. AFTER USE, wipe external surfaces of the Power Pack with clean cloth.

Battery Disposal

WARNING! CONTAINS SEALED LEAD BATTERY. BATTERY MUST BE RECYCLED.

The Power Pack uses a lead-acid battery that must be recycled.

1. Remove all screws from case and open. Cut wires from battery with insulated wire clippers and remove.
2. Disposing of Power Pack must comply with standards for hazardous waste disposal in your area. Contact your local city government office for the nearest hazardous waste disposal area in your community.

Inverter Troubleshooting

Problem	Possible Causes	Possible Solutions
Lack of Inverter power output.	<ol style="list-style-type: none"> 1. Power Pack voltage at or below 12V. 2. Excessive current drawn during operation. 3. Inverter not completely warmed up. 	<ol style="list-style-type: none"> 1. Recharge the Power Pack immediately. 2. Reduce load to 200 watts. 3. Turn off Inverter. Disconnect device. Turn Inverter on and leave running for at least two minutes. Turn off Inverter, quickly plug device to Inverter, making sure device is OFF before connecting. Turn on Inverter and device.
Inverter LED Light off.	<ol style="list-style-type: none"> 1. Inadequate power or excessive voltage drop. 2. Inverter is overloaded. 	<ol style="list-style-type: none"> 1. Check Power Pack and recharge if voltage drops below 12V. 2. Reduce load to 200 watts.
Appliance/device won't operate.	High surge wattage required to start-up.	Toggle the Inverter On/Off switch five times in quick succession to generate the necessary power. If the device does not turn on or start up after five cycles, this Inverter will not work with this device.
Picture breaking up/"snow". (for television)	Signal interference.	<ol style="list-style-type: none"> 1. Place Inverter as far as possible from TV.
Static/noise interference	Using sound system with low quality noise filtering.	Use only with audio system that has a high quality noise filtering system.
 <p>Follow all safety precautions whenever diagnosing or servicing the Power Pack. Disconnect power supply before service.</p>		

PLEASE READ THE FOLLOWING CAREFULLY

THE MANUFACTURER AND/OR DISTRIBUTOR HAS PROVIDED THE PARTS LIST AND ASSEMBLY DIAGRAM (NEXT PAGE) IN THIS MANUAL AS A REFERENCE TOOL ONLY. NEITHER THE MANUFACTURER OR DISTRIBUTOR MAKES ANY REPRESENTATION OR WARRANTY OF ANY KIND TO THE BUYER THAT HE OR SHE IS QUALIFIED TO MAKE ANY REPAIRS TO THE PRODUCT, OR THAT HE OR SHE IS QUALIFIED TO REPLACE ANY PARTS OF THE PRODUCT. IN FACT, THE MANUFACTURER AND/OR DISTRIBUTOR EXPRESSLY STATES THAT ALL REPAIRS AND PARTS REPLACEMENTS SHOULD BE UNDERTAKEN BY CERTIFIED AND LICENSED TECHNICIANS, AND NOT BY THE BUYER. THE BUYER ASSUMES ALL RISK AND LIABILITY ARISING OUT OF HIS OR HER REPAIRS TO THE ORIGINAL PRODUCT OR REPLACEMENT PARTS THERETO, OR ARISING OUT OF HIS OR HER INSTALLATION OF REPLACEMENT PARTS THERETO.

Parts List

Part	Description	Qty	Part	Description	Qty
1	12VDC Outlet	2	18	LED Work Light Cover	4
2	Compressor & Work Light Switch	1	19	LED Work Light	4
3	Battery Test Button	1	20	LED Work Light Element	4
4	Front Plate	1	21	Air Compressor Mounting Plate	1
5	Air Pressure Meter	1	22	Air Compressor w/Hose and Tire Inflator	1
6	Voltmeter	1	23	Left Case	1
7	Air Pressure Meter Mount	1	24	Sealed Lead Acid Battery	1
8	Voltmeter Mount	1	25	Inverter Base	1
9	Outlet Cap	2	26	Inverter	1
10	Air Pressure Meter Cover	1	27	Inverter Fan	1
11	Voltmeter Cover	1	28	Back Case	1
12	Warning LED's Assembly	1	29	12V 40A Fuse Holder	1
13	Clamp Power Switch	1	30	Warning LEDs	2
14	Negative Battery Cable (Black)	1	31	Back Plate	1
15	Negative Battery Clamp (Black)	1	32	230V AC Outlet	1
16	Front Case	1	33	Right Case	1
17	Battery Test Assembly	1	34	Positive Battery Cable (Red)	1
			35	Positive Battery Clamp (Red)	1
			36	Air Hose Compartment Cover	1
			37	USB Connector	1

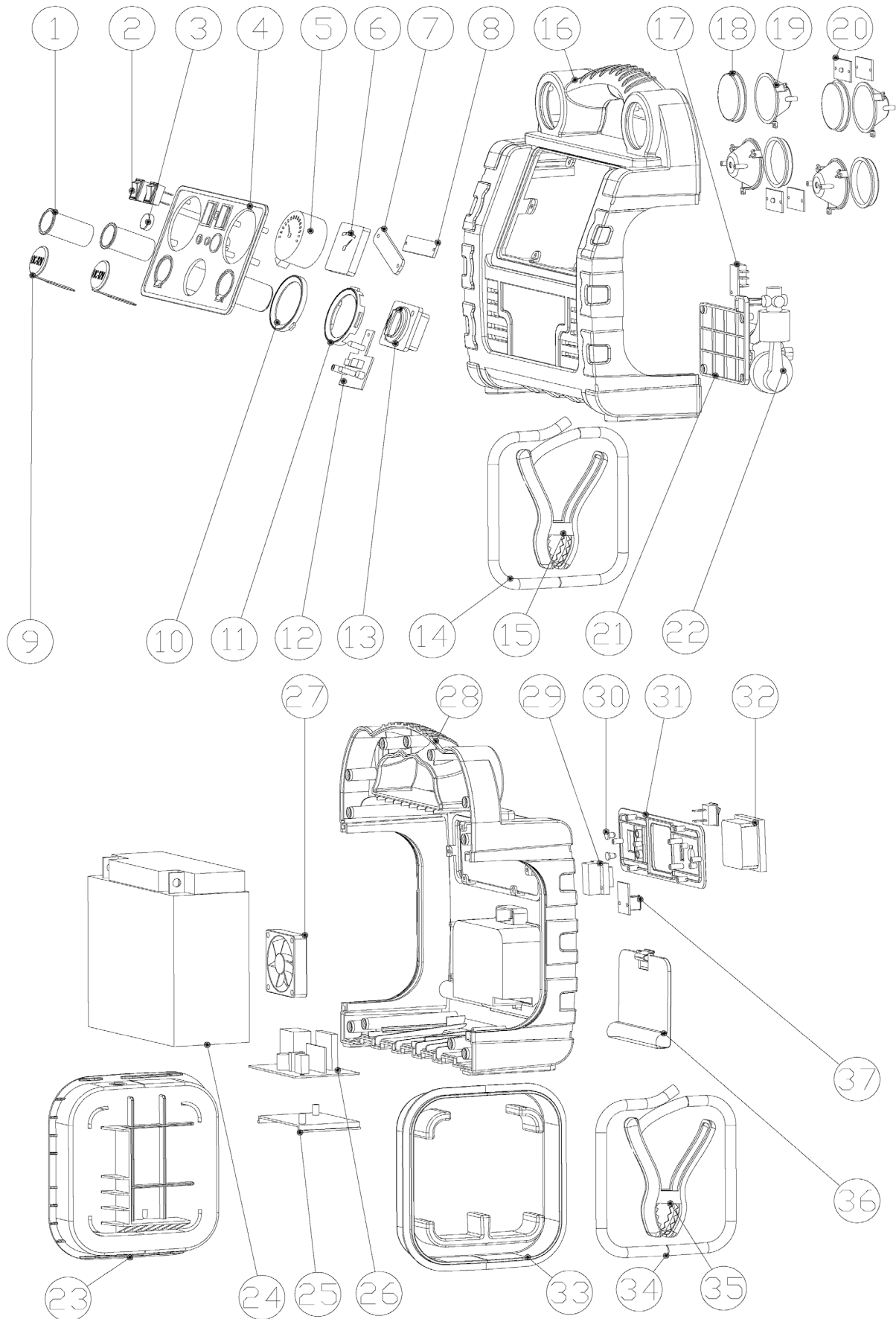

Note: Record date of purchase here if product _____

Note: Some parts are listed and shown for illustration purposes only, and are not available individually as replacement parts. Internal parts are not user-serviceable and are not available.



SAFETY

SETUP

OPERATION

MAINTENANCE



Streetwize:

Ashburton Road West, Trafford Park,
Manchester, M17 1RY

For product support:

E: support@streetwize.co.uk
T: +44 (0)161 447 8597

EU Registered address: **The Ace Supply Co (Europe) Ltd**, 25 Herbert Place, Dublin 2, D02 A098 Republic of Ireland.

www.streetwize.co.uk